

KHWS SERIES

60W WIDE INPUT RANGE



FEATURES

- 60W DIL PACKAGE
- INDUSTRY STANDARD PACKAGE
- 9V-18V,18V-36V,36V-75V WIDE INPUT RANGE
- 100% BURNED IN
- EFFICIENCY UP TO 93%
- UL 94V-0 PACKAGE MATERIAL
- CUSTOM SOLUTIONS AVAILABLE
- 3 YEARS WARRANTY



OUTPUT SPECIFICATIONS

Voltage Setpoint Accuracy	+/-2% max
Over Voltage Protection	Built-in
Temperature Coefficient	+/-0.03%/°C
Ripple & Noise(20MHz BW) ¹	100mVp-p max
Line Regulation ²	+/-0.5% max
Load Regulation ³	+/-0.5% max
Minimum load	10% of Full Load
Short Circuit Protection	Continuous
Short Circuit Restart	Automatic
External Trim Adj. Range	+/-10%
Over Load Protection	150% typ.
Transient Response ⁵	500uS max

INPUT SPECIFICATIONS

Input Voltage Range	2:1
Input Filter	Pi Network
Protection	Fuse Recommended
OVLO(Over Voltage Lockout)	See Page 4
UVLO(Under Voltage Lockout)	See Page 4
OVLO & UVLO Circuit Restart	Automatic

ENVIRONMENTAL SPECIFICATIONS

Operating Temperature	-40 °C to +60 °C
Case Temperature	+90 °C max
Storage Temperature	-55 °C to +100 °C
Humidity	95% max
Cooling	Free-Air Convection

GENERAL SPECIFICATIONS

Efficiency	92% typ.
Isolation Voltage ⁴	1500 VDC min
Isolation Resistance	10 ⁹ ohms min
Isolation Capacitance	2500pF max
Switching Frequency	250KHz typ.
Weight	60g typ.
Case Material	Six-Side Shielded Case
Case Size	50.8mm*50.8mm*11mm
Potting Material	Epoxy(UL94-V0)
Conducted Emissions	EN55022 Class A
Radiated Emissions	EN55022 Class A

ALL SPECIFICATIONS TYPICAL AT NOMINAL LINE, FULL LOAD, AND 25 °C UNLESS OTHERWISE NOTED.

¹ Measured with 1uF ceramic capacitor connect to the output pins.

² High Line to Low Line.

³ Load Regulation is for output load current change from 10% to 100%.

⁴ For 10 seconds.

⁵ 50% Step Load Change.

● **SELECTION GUIDE**
2:1 46W~60W OUTPUT

MODEL NUMBER	INPUT VOLTAGE (VDC)	OUTPUT VOLTAGE (VDC)	OUTPUT CURRENT (mA)	INPUT ⁶ CURRENT(mA)		EFF (%) ⁷	CAPACITOR LOAD (Max)
				FULL LOAD	NO LOAD		
KHWS-1203.3	9-18	3.3	14000	4231	160	91	1000uF
KHWS-1205	9-18	5	12000	5505	160	91	1000uF
KHWS-1212	9-18	12	5000	5430	160	92	220uF
KHWS-1215	9-18	15	4000	5350	160	93	100uF
KHWS-2403.3	18-36	3.3	14000	2092	100	92	1000uF
KHWS-2405	18-36	5	12000	2730	100	92	1000uF
KHWS-2412	18-36	12	5000	2701	100	93	220uF
KHWS-2415	18-36	15	4000	2690	100	93	100uF
KHWS-4803.3	36-75	3.3	14000	1046	50	92	1000uF
KHWS-4805	36-75	5	12000	1345	50	93	1000uF
KHWS-4812	36-75	12	5000	1345	50	93	220uF
KHWS-4815	36-75	15	4000	1338	50	93	100uF

Note: Other input to output voltages may be available. Please contact factory.

● **PART NUMBERS STRUCTURE**

Model Name	Difference
KHWv-x1x2	<p>KH=Series Name</p> <p>W=Wide Input Range</p> <p>v=Type of output voltage (S=single output)</p> <p>x1=Input voltage(9~18V ; 18~36V ; 36~75V)</p> <p>x2=Output voltage(03.3 ; 05 ; 12 ; 15)</p> <p>zzz= 0~9 , A~Z or blank for market purpose.</p>

⁶ NOMINAL INPUT VOLTAGE.

⁷ NOMINAL INPUT VOLTAGE, FULL LOAD.

● SIMPLIFIED SCHEMATIC

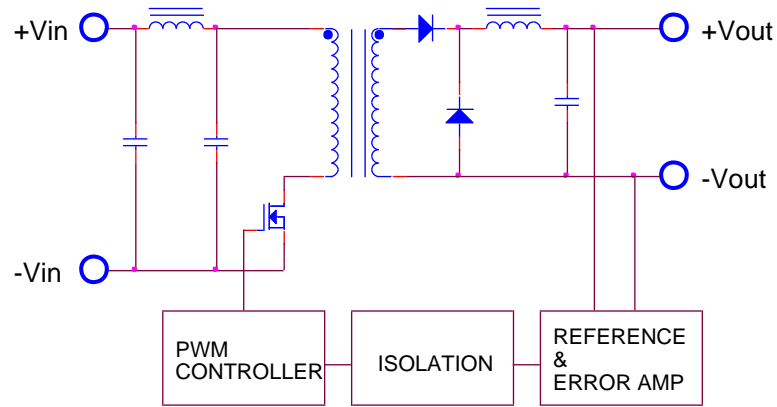

● MECHANICAL DIMENSIONS

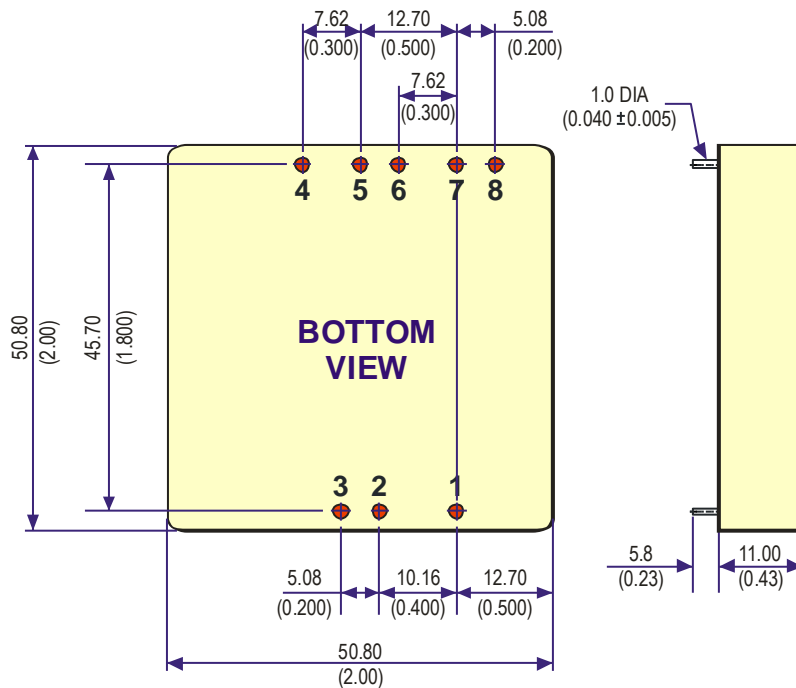

PIN	SINGLE
1	Remote On/Off
2	-Vin
3	+Vin
4	-Sense
5	+Sense
6	+Vout
7	-Vout
8	Trim

NOTE:

All Dimensions In mm(Inches)

Tolerance .X or .XX= ±0.5mm

All dimensions in mm(inches).

Remote On/Off Control			
Control Input	PIN1	Control Common	PIN2
Control Voltage		Converter Shutdown Idle Current	10mA
ON	>+2.5VDC or Open Circuit	Logic Compatibility	CMOS or Open
OFF	<+0.5VDC or Jumper to PIN2		Collector TTL

● INPUT OPERATING VOLTAGE

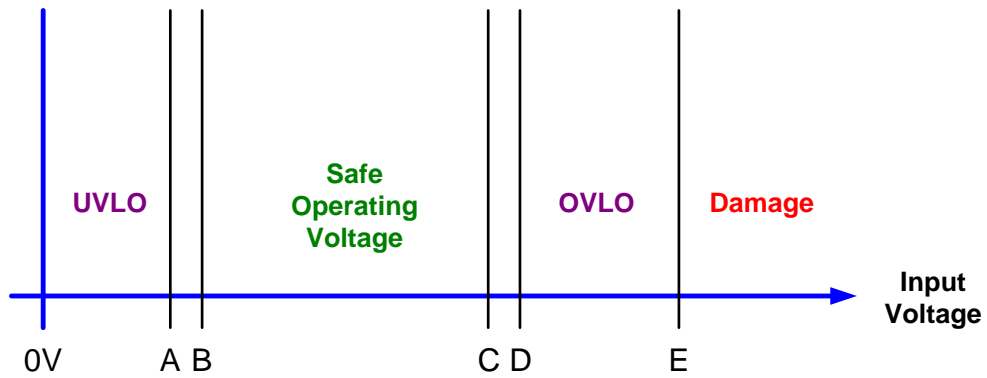

	A	B	C	D	E
KHWS-12****	8V typ.	9V	18V	20V typ.	25V
KHWS-24****	16V typ.	18V	36V	40V typ.	50V
KHWS-48****	34V typ.	36V	75V	80V typ.	100V

● TYPICAL APPLICATIONS

FIXED VOLTAGE OUTPUT

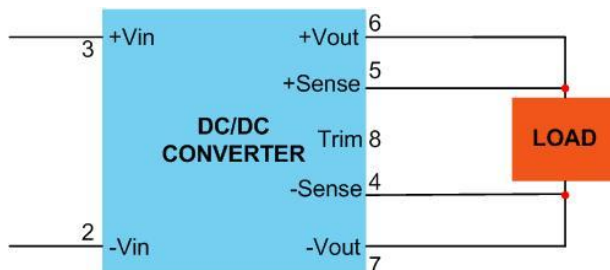

TRIM CONNECTIONS USING A TRIMPOT

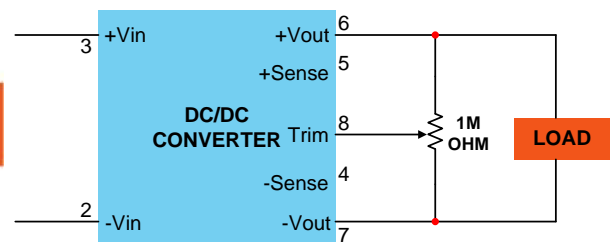

FIXED-VALUE TRIM DOWN RESISTOR

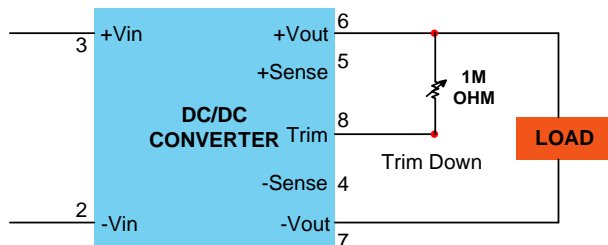

FIXED-VALUE TRIM UP RESISTOR

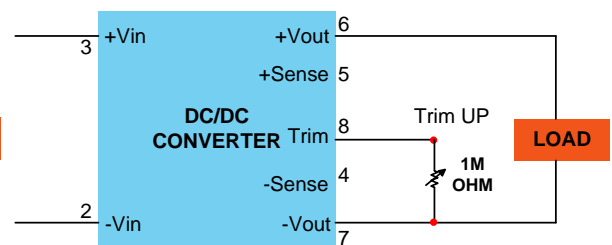

● RECOMMENDED FOOTPRINT DETAILS

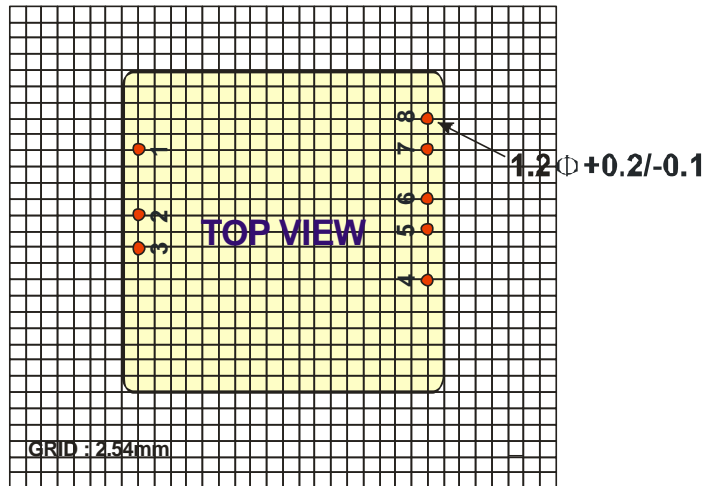

● TYPICAL PERFORMANCE CURVES

Specifications typical at $T_a=25^\circ\text{C}$, nominal input voltage , rated output current unless otherwise specified.

OUTPUT LOAD VS EFFICIENCY

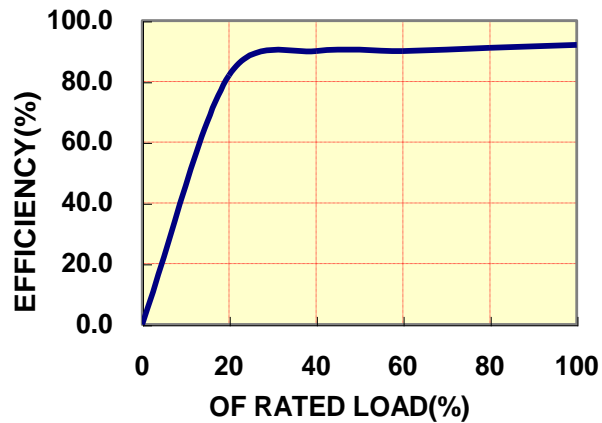

TEMPERATURE DERATING

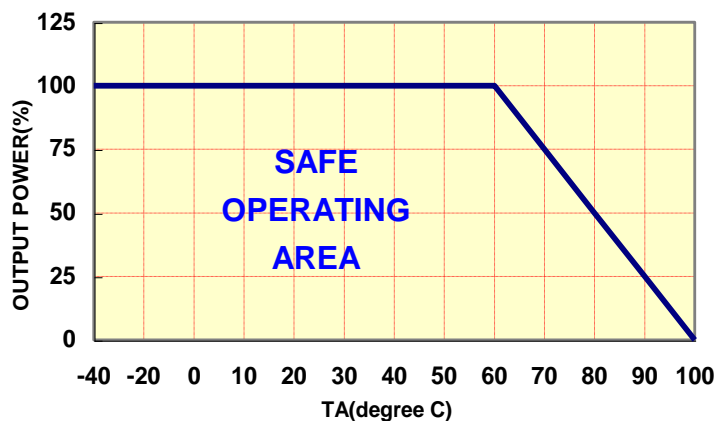

● INPUT FUSE SELECTION GUIDE

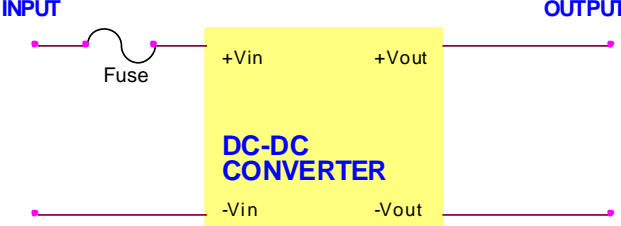
9-18V INPUT VOLTAGE(VDC)	18-36V INPUT VOLTAGE(VDC)	36-75V INPUT VOLTAGE(VDC)
15000mA Slow-Blow Type	9000mA Slow-Blow Type	4000mA Slow-Blow Type
		

Note: Certain applications may require the installation of external fuse in front of the input.

KHWS SERIES APPLICATION NOTES:

EXTERNAL CAPACITANCE REQUIREMENTS:

External output capacitance is not required for operation; however it is recommended that 10uF MLCC and 0.1uF ceramic capacitance be selected for reduced system noise.

Additional output capacitance may be added for increased filtering, but should not exceed 1000uF.

Negative Outputs:

A negative output voltage may be obtained by connecting the +OUT to circuit ground and connecting –OUT as the negative output.

Remote ON/OFF:

The remote ON/OFF pin may be left floating if this function is not use. It is recommended to drive this pin with an open collector arrangement or a relay contact. When the ON/OFF pin is pulled low with respect to the –Vin , the converter is placed in a low power drain state.

Output TRIM:

The TRIM pin may be used to adjust the output +/-10% from the nominal setting .this function allows adjustment for voltage drops in the system wiring. If the TRIM function is not required the pin may be left floating.